

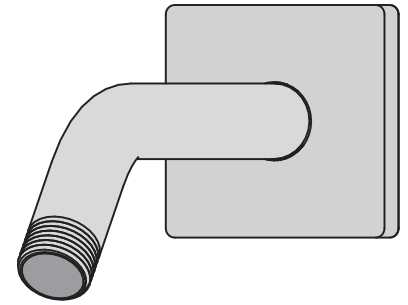

Shower Arm, 300SQ



Installation Brief

Product Highlights

- Shower arm with square 2-1/2 inch flange

Need Help?

Contact Symmons customer service at
(800) 796-6667, (781) 848-2250
Email: customerservice@symmons.com
Monday - Friday 8:00 am - 7:30 pm EST

 Please check Symmons website for technical help,
the latest product information and warranty policy.
Website: www.symmons.com/service

Parts Assembly *Shower Arm, 300SQ*

*Shower arm
300SQ*

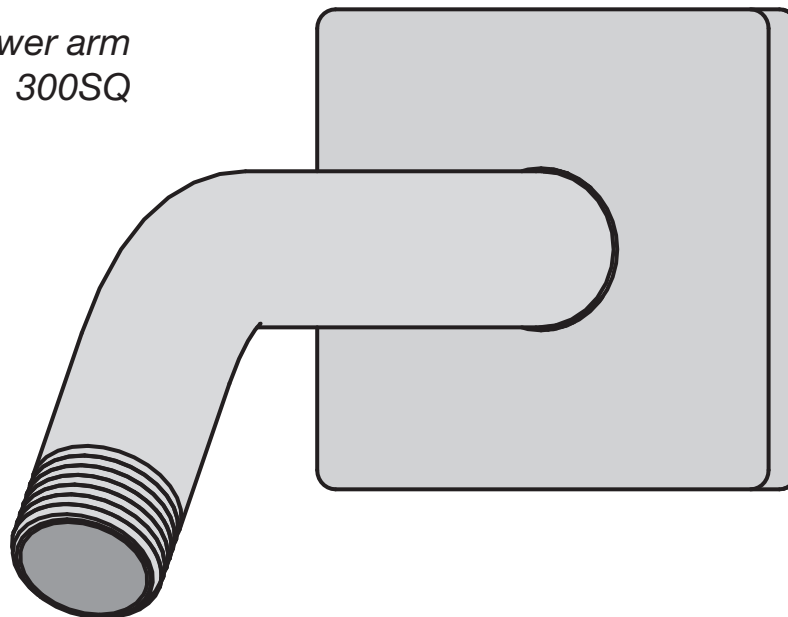

Dimensions Shower Arm, 300SQ

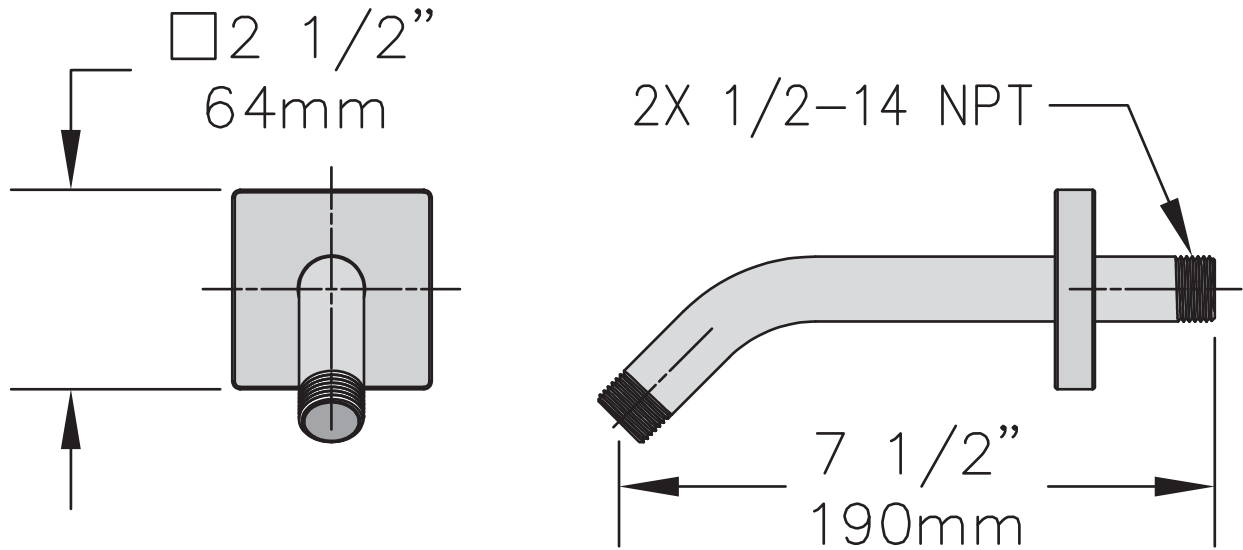

Note: *Dimensions subject to change without notice.*